

PRESSURE SWITCH (EXPLOSION PROOF)

PISTON TYPE

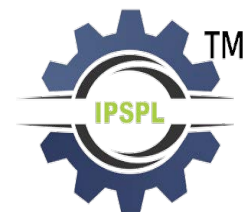

IPS-PS-05

SPECIAL FEATURES

- ATEX APPROVED
- HIGH ACCURACY & REPEATABILITY
- SS WETTED PARTS
- SET POINT LOCKING
- HIGHLY RELIABLE
- DIAPHRAGM SEALS (OPTIONAL)

APPLICATIONS

- BOILER, FURNACE
- OIL & GAS, CONVENTIONAL & NUCLEAR POWER PLANTS, MINES, IRON & STEEL PLANTS, REFINERIES, PETROCHEMICAL, HYDRAULIC, FOOD & PHARMACEUTICAL, CHEMICAL & FERTILIZER, CEMENT, GLASS, PAINT, PULP & PAPER, MARINE INDUSTRIES AND OTHER HAZARDOUS APPLICATIONS.

DIMENSIONAL DETAILS

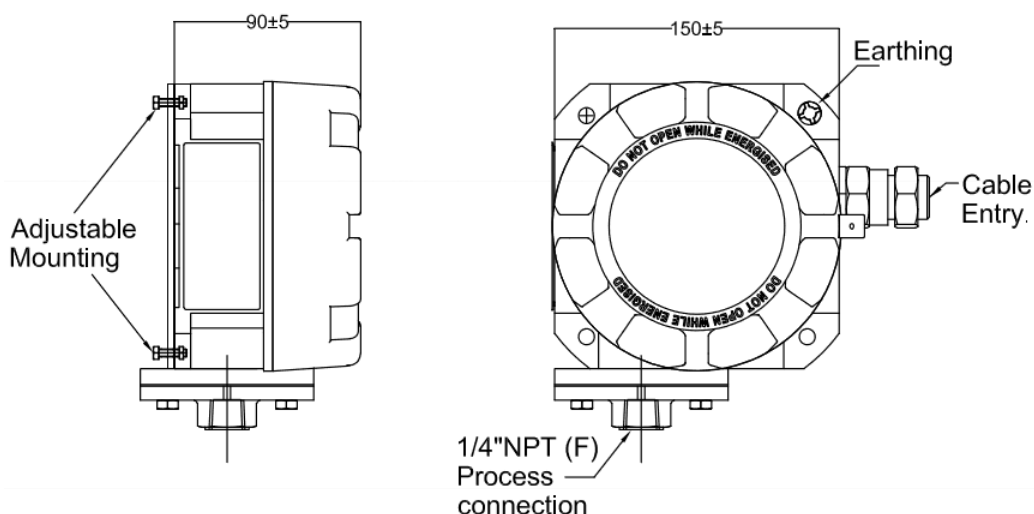

Notes : • Drawings are not to scale.
• All Dimensions are in mm.

TECHNICAL SPECIFICATIONS - STANDARD VERSION

Repeatability	: ± 1% F. S.
Scale Accuracy	: ± 3% F. S.
Scale	: bar (Inside Enclosure)
Range	: Refer "How to order"
Set Point	: Between 20 to 80% F. S. for better performance
Over pressure Limit	: 150% of F. S.
Differential	: Fixed
Mounting	: Bottom / Panel
Process Connection	: 1/4" NPT (F)
Enclosure Protection	: W/P to IP 65 & Explosion proof, Class 1, Div. 2, Gas Groups B, C & D (ExII2G, Eex d IIC T6)
Enclosure Material	: Die Cast aluminum
Maximum Process Temperature	: 150 °C
Ambient Temperature	: -10 to 60 °C
Switch	: 1 SPDT, Snap Action Micro Switch
Switch Rating	: 15 A, 250 VAC, 0.2 A, 220 VDC
High Voltage Strength	: 0.5 to 0.6 KV between open contacts and 2 KV between contacts and body
Insulation Resistance	: >100 M ohms at 500 V
Sensing Element	: Piston
Wetted Parts	: AISI 316 SS
Cable Gland	: ½" NPT (M) double compression
Conformity	: BS 6134



Industrix Precise Solutions Private Limited

Room No – 303, Bhumika Residency, Plot No-21, Sector-20, Roadpali, Kalamboli, Panvel (Tal.), Raigad (Dist.), Maharashtra, India – 410218.

Mobile: +91 99309 98399 / +91 99674 97447

E-mail: admin@ipspl.in / sales@ipspl.in Website: www.ipspl.in

CIN : U52399MH2021PTC368555

HOW TO ORDER

BASIC MODEL

RANGE

Ordering Code	Range (bar)	Ordering Code	Range (bar)	Ordering Code	Range (bar)
P060	5 to 60	P160	10 to 160	P400	40 to 400
P100	10 to 100	P250	10 to 250	P600	60 to 600

WETTED PARTS

C6 AISI 316 SS (Standard) SL AISI 316L SS

DIFFERENTIAL

F FIXED (Standard)

TYPE OF MICRO SWITCH

1S 1 SPDT 2S 2 SPDT 1D 1 DPDT

MICRO SWITCH RATING

Switch Code	Description	AC Rating	AC Rating (Resistive)	DC Rating (Inductive)	Available on 1 SPDT	Available on 2 SPDT
GPL	Low Dead band and Fixed	15 A 250 V	2 A 24 V 0.4 A 110 V 0.2 A 220 V	2 A 24 V 0.4 A 110 V 0.2 A 220 V	Fixed Differential of ZPD, ZPP, ZDD	Fixed Differential of ZPD, ZPP, ZDD
GPH	Standard Dead Band	15 A 250 V	6 A 24 V 0.5 A 110 V 0.25 A 220 V	5 A 24 V 0.05 A 110 V 0.03 A 220 V	Fixed Differential of ZPD, ZPP, ZDD	Fixed Differential of ZPD, ZPP, ZDD
GPA	Adj. Differential Micro Switch	15 A 250 V			Adj. Differential of ZPD, ZPP, ZDD	NA
GPG	Gold Plated Contact	1 A 125 V	0.5 A 28 V		Fixed Differential of ZPD, ZPP, ZDD	Fixed Differential of ZPD, ZPP, ZDD
SES	Environmentally sealed Silver Contact	15 A 250 V	0.4 A 125 V		Fixed Differential of ZPD, ZPP, ZDD	Fixed Differential of ZPD, ZPP, ZDD
SEG	Environmentally sealed Silver Contact		1 A 28 V		Fixed Differential of ZPD, ZPP, ZDD	Fixed Differential of ZPD, ZPP, ZDD
HSS	Hermetically sealed Silver Plated	4 A 230 V	3 A 28 V	2 A 24 V	Fixed Differential of ZPD, ZPP, ZDD	Fixed Differential of ZPD, ZPP, ZDD
HSG	Hermetically sealed Gold Plated	1 A 125 V	NA	NA	Fixed Differential of ZPD, ZPP, ZDD	Fixed Differential of ZPD, ZPP, ZDD
HDC	High DC Rating	10 A 125 V	10 A 125 V	6 A 125 V	Fixed Differential of ZPD, ZPP, ZDD	Fixed Differential of ZPD, ZPP, ZDD
DPD	DPDT Micro Switch	10 A 125 V	0.2 A 250 V		Fixed & Adjustable Differential of ZPD, ZPP, ZDD	NA

CALIBRATION

I INCREASING D DECREASING (Not Applicable for Adj. Differential)

PROCESS CONNECTIONS (* Please mention the flange face and flange finish)

Through Adaptors		Flanged (As per ANSI B 16.5)*							
2NM	1/4" NPT (M)	3BM	3/8" BSP (M)	B09	1/2" 150 #	B21	1" 150 #	B39	2" 150 #
2NF	1/4" NPT (F) (Standard)	3BF	3/8" BSP (F)	B10	1/2" 300 #	B22	1" 300 #	B40	2" 300 #
		4BM	1/2" BSP (M)	B11	1/2" 600 #	B23	1" 600 #	B41	2" 600 #
		4BF	1/2" BSP (F)	B15	3/4" 150 #	B33	1 1/2" 150 #	B51	3" 150 #
		4NM	1/2" NPT (M)	B16	3/4" 300 #	B34	1 1/2" 300 #	B52	3" 300 #
		4NF	1/2" NPT (F)	B17	3/4" 600 #	B35	1 1/2" 600 #	B53	3" 600 #

CABLE ENTRY

DTE	3/4" ET DUEL ENTRY WITH ONE ENTRY PLUGGED	ECB	3/4" ET DCCG BRASS	DCS	3/4" ET DCCG WITH ONE ENTRY PLUGGED
DNP	1/2" NPT (F) WITH ONE ENTRY PLUGGED	NPB	1/2" NPT DCCG BRASS	DPS	1/2" NPT DCCG WITH ONE ENTRY PLUGGED
ECS	3/4" ET DCCG SS	2NP	1/2" NPT (F)	NPS	1/2" NPT DCCG SS
ETE	3/4" ET				

OPTIONS

PW	CALIBRATION CERTIFICATE	WM	WALL MOUNTING BRACKET (STEEL PLATED)
SX	SS TAG PLATE	PM	2" PIPE MOUNTING
TF	CONFORMITY AS PER NACE MR 0175	JU	2" PIPE/YOKE MOUNTING BRACKET & 'U' CLAMP (AISI 304 SS)
GH	MATERIAL TEST CERTIFICATES***	FN	2" PIPE/YOKE MOUNTING BRACKET & 'U' CLAMP (AISI 316 SS)
SG	OXYGEN SERVICE		
PU	CALIBRATION CERTIFICATE TRACEABLE TO NATIONAL/INTERNATIONAL STANDARDS		

*** MATERIAL TEST CERTIFICATES WILL BE PROVIDED FOR WETTED PARTS ONLY WITH CHEMICAL COMPOSITION TESTING. FOR OTHERS, PLEASE CONSULT FACTORY.

ACCESSORIES (Refer Individual Datasheet for complete specifications)

EB	COOLING TOWER	ED	OVER LOAD PROTECTOR	EG	SNUBBER
EC	GAUGE COCK	NV4	NEEDLE VALVE	EH	SYPHON
DS	DIAPHRAGM SEALS	EL	COOLING CAPILLARY	VM	MANIFOLDS

Note : In 2 SPDT Instruments, there may be an error of max ± 2% F. S. between Micro Switches at the set point.

Modifications may take place and materials specified may be replaced by others without prior notice due to continuous developments.

