

# DIAPHRAGM SEAL

## DIRECT COUPLED TYPE (COMPACT DESIGN)



IPS-DS-02

### SPECIAL FEATURES

- ALL STAINLESS STEEL CONSTRUCTION
- COMPACT DESIGN
- LOW COST VERSION
- THE DIAPHRAGM IS WELDED TO THE BODY TO ENSURE SEPARATION OF THE FILLING FLUID FROM THE PROCESS MEDIUM

### APPLICATIONS

DIAPHRAGM SEALS ARE DESIGNED TO ISOLATE THE SENSING ELEMENT OF PRESSURE GAUGES AND PRESSURE SWITCHES FROM PROCESS FLUIDS THAT THEY MAY BE CORROSIVE, VISCOUS, SEDIMENTOUS AND / OR WITH A HIGH TEMPERATURE.

### SPECIFICATIONS

#### STANDARD VERSION

(COMPATIBLE WAAREE MODELS : AD & AT ( NS 50 mm & 63 mm)

Range	: 1 kg/cm <sup>2</sup> to 21 kg/cm <sup>2</sup>
Process Temperature	: - 40 °C to 200 °C or as per fill fluid
Instrument Connection	: 1/4" BSP (F)
Process Connection	: 1/4" BSP (M)
Fill Fluid	: Silicon Oil - DC 200

Diaphragm	: AISI 316L SS
Body	: AISI 316 SS



### DIMENSIONS - STANDARD VERSION

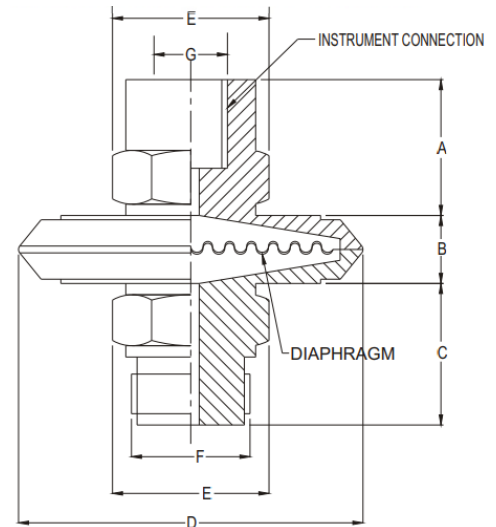

A	B	C	D	E	F	G	Approx. Wt. #
26	14	23	62	HEX A/F 19	1/4" BSP(M)	1/4" BSP(F)	260.0

(# Weight in grams with box for Standard Model.)

### HOW TO ORDER

#### BASIC MODEL

#### CODE

#### OPTIONAL EXTRAS

#### INSTRUMENT CONNECTION

VN 1/4" BSP (F) (Standard) VO 1/4" NPT(F)

#### BODY

CL AISI 316 SS (Standard)

#### DIAPHRAGM

UJ AISI 316L SS (Standard)

#### PROCESS CONNECTION

WS 1/4" BSP (M) (Standard) WY 1/4" NPT (M)

#### FILLING FLUIDS (\*Consult factory for specifications, price and delivery.)

<b>US</b> FLUROLUBE 4.2 [-45 to 175 °C]	<b>UY</b> SILICON DC 704 [10 to 337 °C]
<b>UT</b> FLUROLUBE 6.3 [-40 to 235 °C]	<b>UZ</b> SILICON DC 710 [7 to 371 °C]
<b>UU</b> FLUROLUBE FS-5 [-28 to 148 °C]	<b>VA</b> SYLTHERM 800 [-40 to 315 °C]
<b>UV</b> FOOD GRADE OIL [-20 to 140 °C]	<b>VB</b> SYLTHERM XLT [-100 to 260 °C]
<b>UX</b> SILICON DC 200 [-40 to 205 °C] (Standard)	<b>VC</b> HALOCARBON OIL*

#### OTHER OPTIONS

TB HELIUM LEAK TEST TC DRY SEAL ONLY WITHOUT INSTRUMENT GH MATERIAL TEST CERTIFICATES\*

\* MATERIAL TEST CERTIFICATES WILL BE PROVIDED FOR WETTED PARTS ONLY WITH CHEMICAL COMPOSITION TESTING. FOR OTHERS, PLEASE CONSULT FACTORY.

Note : Specifications and dimensions given in this product catalogue represents the state of engineering at the time of printing.

Modifications may take place and materials specified may be replaced by others without prior notice.

IPS-PS-02

XX

XX

XX

XX

XX

XX



## Industrix Precise Solutions Private Limited

Room No – 303, Bhumika Residency, Plot No-21, Sector-20, Roadpali, Kalamboli, Panvel (Tal.), Raigad (Dist.), Maharashtra, India – 410218.

Mobile: +91 99309 98399 / +91 99674 97447

E-mail: [admin@ipspl.in](mailto:admin@ipspl.in) / [sales@ipspl.in](mailto:sales@ipspl.in) Website: [www.ipspl.in](http://www.ipspl.in)

CIN : U52399MH2021PTC368555